

Linear Precoder Design with Spatial Multiplexing for MIMO System

**Abdulla Al Suman^a, Md. Kafil Uddin^b, Lakshman Saha^c, Tanvir Ahmed^d
and Md. Munjure Mowla^e,**

^a Assistant Professor, Dept. of ETE, Rajshahi University of Engineering & Technology(RUET), Rajshahi, Bangladesh
suman.ete.ruet@gmail.com

^b Senior System Engineer, Dept. of Planning Design and Dimensioning, Technology, Grameen Phone Ltd., Dhaka, Bangladesh
kafilruet@gmail.com

^c Senior System Engineer, Dept. of SOC, Operations, Technology, Grameen Phone Ltd., Dhaka, Bangladesh
lakshman.ete@gmail.com

^d Assistant Professor, Dept. of EEE, Rajshahi University of Engineering & Technology(RUET), Rajshahi, Bangladesh
tanvir_1008@yahoo.com

^e Assistant Professor, Dept. of ETE, Rajshahi University of Engineering & Technology(RUET), Rajshahi, Bangladesh
rhonece@gmail.com

Abstract. This paper presents linear precoder design with spatial multiplexing for multiple-input multiple-output (MIMO) system with perfect knowledge of channel state information at transmitter (CSIT) restoring the low complexity at both transmitter and receiver, subject to a total transmit power constraint. Assuming Rayleigh fading channel and using a maximum-likelihood detector at receiver, we show that the proposed precoder is a function of noise variance and the eigenvectors of the estimated channel matrix. The singular value decomposition (SVD) method and standard water filling algorithm are used for designing the precoder and beam power allocation respectively. Simulation results are provided to illustrate the significance performance gain achieved by using the proposed precoder. The precoder shows the bit error rate (BER) of $10^{-5.5}$ at 2dB signal to noise ratio (SNR). The precoder may be promising in wireless data transmission application especially for worldwide interoperability for microwave access (WIMAX).

Keywords: multiple-input multiple-output, spatial multiplexing, singular value decomposition, linear precoder, standard water filling algorithm.

1. INTRODUCTION

Multiple input multiple output (MIMO) systems have drawn a lot of attention over the last decade thanks to their capability of boosting the channel capacity without the need of additional bandwidth or power. MIMO systems exploit spatial degrees of freedom provided by multiple antennas at both ends of a communication link to support simultaneous multiple data streams (Le-Nam Tran 2012). In order to achieve high data rate over MIMO channels, one important signal processing solution is by using space-time block code (STBC) (V. Tarokh 1998, V. Tarokh 1999) that performs coding across both spatial and temporal dimensions, so as to utilize maximum possible diversity advantage and coding advantage without sacrificing channel bandwidth. The another significant processing solution for achieving high data rate over MIMO channel is by using spatial multiplexing at the cost of

low complexity than STBC. Spatial multiplexing is a method of increasing bit rate by transmitting parallel, unique symbol streams in space using multiple transmit antennas and multiple receive antennas (Samuel C. Yang 2010). Due to the fact that channel state information at transmitter (CSIT) is not required for space-time code, recent researches have mainly focused on the scenarios in which channel state information at receiver (CSIR) is available. However in the case where CSIT can be feedback estimated in frequency division duplex (FDD)/time division duplex (TDD) systems, the CSIT can be exploited for optimum precoder and transceiver designs (W. Huang 2006).

Recent information theoretic studies have proved that dirty paper coding (DPC) is the capacity-achieving transmission technique for MIMO downlink channels (H. Weingarten 2006, S. Vishwanath 2003, P. Viswanath 2003). However, implementing DPC is still a challenging task because of its successive nature of encoding and decoding especially when the number of users is large. Furthermore, DPC is very sensitive to channel errors. To avoid the complexity of DPC, there is a large interest in developing low complexity precoding methods (Le-Nam Tran 2012).

Furthermore, MIMO technique also offers research challenges due to inherent multiuser interference (MUI) in such system. Usually, an efficiently designed precoder can significantly cancel MUI in a MIMO system. When the channel conditions are known to MIMO transmitter, it is possible to design precoders such that MUI at the receiver is completely nullified (Umesh Phuyal 2012). Due to the fact that the co-channel interference is hard to be managed by the receiver operation and more importantly, capacity of interference channel can be made equivalent to capacity without interference, pre-cancellation of the interference via the precoding at the transmitter has received much attention in recent years (Jungyong Park 2012).

In this paper, a linear precoder design is proposed for general MIMO systems without STBC in a spatial multiplexing system. The precoder performs beam power allocation using water filling algorithm based on only the eigenvectors of the Rayleigh fading wireless channel matrix. The total power of the transmitter is constraint. The precoder dispatches the symbols into orthogonal beam directions (patterns) using singular value decomposition of the Rayleigh fading wireless channel matrix. In this paper, we assume perfect channel knowledge at the transmitter. At the receiver, we have used maximum-likelihood detector. Simulation results verify that the proposed precoder design is able to improve the performance of the MIMO system.

2. SYSTEM MODEL

We consider spatial multiplexing MIMO system with M_t transmit and M_r receive antennas as shown in Fig.1. The channel is modeled as an uncorrelated Rayleigh flat fading channel and is denoted by a $M_r \times M_t$ matrix \mathbf{H} with i.i.d. (independent and identical distributed), zero mean, unit variance complex Gaussian entries.

The randomly generated binary message sequence is encoded by a convolutional encoder of rate $r = 1/2$, interleaved by random interleaver and converted to M -ary symbols. The serial-to-parallel converter converts the original symbol stream into M_t symbol streams. The transmitted symbol vector \mathbf{c} ($M_t \times 1$) is first preprocessed by the Precoder matrix \mathbf{F} ($M_t \times M_t$). Then the preprocessed symbol vector $\mathbf{F}\mathbf{c}$ ($M_t \times 1$) is sent by the M_t transmit antennas and is degraded by the channel matrix \mathbf{H} ($M_r \times M_t$). The degraded symbol vector at the receive antennas is $\mathbf{H}\mathbf{F}\mathbf{c}$ ($M_r \times 1$). A postprocessing matrix \mathbf{U}_H^* ($M_r \times M_r$) is applied to the degraded symbol vector $\mathbf{H}\mathbf{F}\mathbf{c}$ as well as the noise vector \mathbf{n} ($M_r \times 1$). Thus, the received symbol vector \mathbf{y} ($M_r \times 1$) can be written as (Samuel C. 2010)

$$\mathbf{y} = \mathbf{U}_H^*(\mathbf{H}\mathbf{F}\mathbf{c} + \mathbf{n}) \quad (M_r \times 1). \tag{1}$$

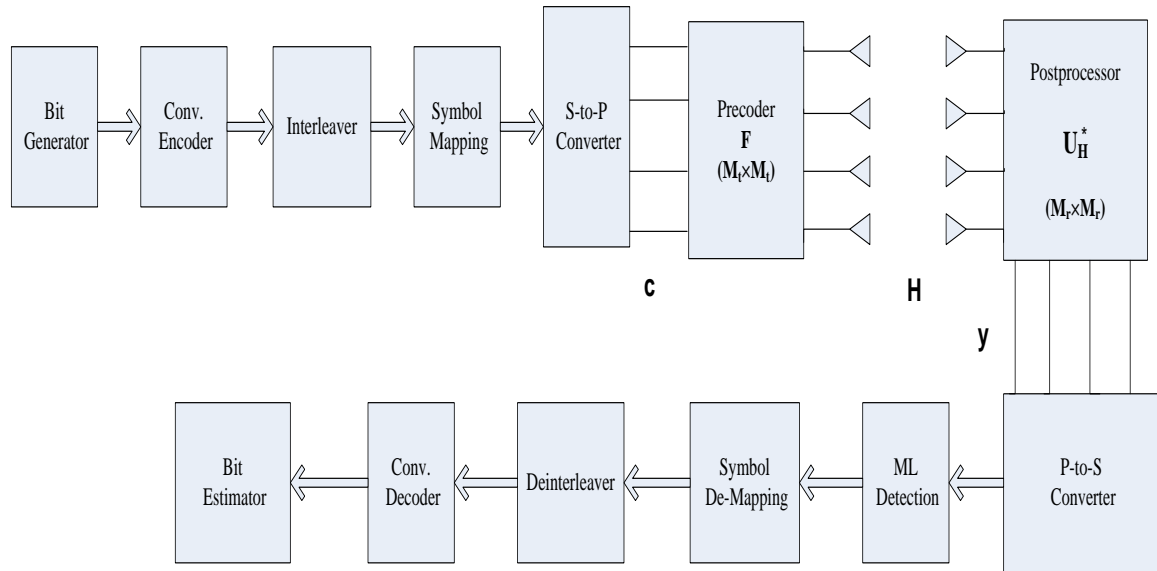

Fig.1. The Communication System model for Precoding.

3. LINEAR PRECODER DESIGN

A linear precoder functions as an input shaper and a beamformer with one or multiple beams with per-beam power allocation. Consider the singular value decomposition of the precoder matrix \mathbf{F} (Ezio Biglieri 2006)

$$\mathbf{F} = \mathbf{U}_F \mathbf{D} \mathbf{V}_F^* . \tag{2}$$

The orthogonal beam directions (patterns) are the left singular vectors \mathbf{U}_F ; the beam power loadings are the squared singular values \mathbf{D}^2 . The right singular vectors \mathbf{V}_F , termed the input shaping matrix, combine the input symbols from the encoder to feed into each beam. The beam directions and power loadings are influenced by the CSIT, the design criterion and in many cases the SNR but the optimal input-shaping matrix (the precoder right singular vectors), which is independent of the CSIT (Ezio Biglieri 2006). In this paper, we have assumed the optimal input-shaping matrix as the identity matrix and it is omitted for using special multiplexing.

4. PRECODING ON PERFECT CSIT

Given perfect CSIT, the MIMO channel can be decomposed into r independent parallel additive white noise channels, where $r = \text{rank}(\mathbf{H}) \leq \min(M_R, M_T)$. To demonstrate this, let the singular value decomposition (SVD) of the channel be (Ezio Biglieri 2006)

$$\mathbf{H} = \mathbf{U}_H \mathbf{\Sigma} \mathbf{V}_H^* . \tag{3}$$

Then, multiplying the signal at the transmitter with \mathbf{V}_H and at the receiver with \mathbf{U}_H^* results in the parallel channels corresponding to the original channel eigen-modes, as shown in Fig.1. The r parallel channels can be processed independently, each with independent modulation

and coding; thus, allowing per-mode rate control. The parallel channel decomposition helps to significantly simplify the receiver signal processing, as the receiver now needs to perform only scalar rather than complex joint detection and decoding (Ezio Biglieri 2006).

4.1 Optimal beam directions

The parallel channel decomposition implies that the precoder left singular vectors, or the beam directions are matched to the channel right singular vectors (Ezio Biglieri 2006)

$$\mathbf{U}_F = \mathbf{V}_H. \tag{4}$$

These beam directions are optimal for all precoding criteria, including the capacity, the error exponent, the average PEP, the PEP per-distance, and the MSE. The optimality can be established using matrix inequalities that show function extrema obtained when the matrix variables have the same eigenvectors. Therefore, the optimal beam directions are given by the eigenvectors of $\mathbf{H}^* \mathbf{H}$, or the channel eigen-directions (Ezio Biglieri 2006).

4.2 Optimal power allocation

In contrast to the beam directions, the optimal power allocation across the beams varies for each design criterion and is a function of the SNR. The power \mathbf{p}_i on the beams are the eigen values of $\mathbf{F} \mathbf{F}^*$, normalized for unit sum. The precoder singular values can be established from the beam power as $\mathbf{d}_i = \sqrt{\mathbf{p}_i}$.

The power allocation is a function of the channel. For convenience, we define

$$\lambda_i = \lambda_i(\mathbf{H}^* \mathbf{H}). \tag{5}$$

For the capacity criterion, power is allocated among the M_i beams via the standard water-filling solution (T. Cover 1991). The power allocated to channel i is (Ezio Biglieri 2006)

$$\mathbf{p}_i = \left(k - \frac{N_0}{\lambda_i} \right)_+ \tag{6}$$

Where k is chosen such that $\sum_i p_i = P$, the total transmit power and N_0 is the noise power per spatial dimension. The notation $(\cdot)_+$ means that the expression takes the value inside the parentheses if this value is positive; otherwise, it is zero (Ezio Biglieri 2006).

5. NUMERICAL RESULT AND DISCUSSION

In this section, we provide simulation result to illustrate the performance of the proposed precoder. We find the precoding matrix according to the theory. We use SVD method for designing the precoder. The bit error rate (BER) is used as the performance measurement.

5.1 Simulation setup

The MIMO channel is assumed to be constant across a special multiplexing system for one symbol period. The elements of channel matrix \mathbf{H} is modelled as zero mean i.i.d. Rayleigh variables assumed to be constant over one time slots. The numerical study considers uncorrelated channels. A convolutional encoder of rate $r=1/2$ is used for channel coding and a random interleaver is used for interleaving. The simulation is done for QPSK modulation

scheme and ML- detection technique is used in the receiver. The four transmitting antenna and four receiving antenna are used in the simulation.

5.2 Performance analysis

To demonstrate the performance of proposed scheme, we compare it with a precoding and power allocation (PA) method existing in the literature (W. Huang 2006, O. Simeone 2003, Ami Wiesel 2006, Eddy Chiu 2012). The existing method uses SVD-based approach using partial CSIT and follows water-pouring policy in a STBC MIMO system subjected to total transmit power constraint (W. Huang 2006). A transceiver structure for MIMO system comprising linear/non-linear precoding/decoding for long-term CSIT has been proposed in the existing literature (O. Simeone 2003). In (Ami Wiesel 2006), a linear precoder design for fixed MIMO receivers has been considered using standard conic optimization packages. The existing method has been considered MIMO precoder design at the source and relay nodes using statistical CSI for correlated MIMO channels and partial decode-and-forward (PDF) protocol, matched to practical minimum mean-square-error successive interference cancellation (MMSE-SIC) receivers at the relay and destination nodes (Eddy Chiu 2012). For all of the proposed and existing schemes under consideration, we limit transmit power within their budget constraints.

5.3 Simulation result

First, we analyze the effect of spatial multiplexing over STBC in MIMO system and plot the corresponding bit error rate (BER) in Fig. 2. In this simulation, we have used QPSK modulation for symbol mapping. Therefore the circuit complexity in the transmitter side is comparatively lower than the other modulation scheme such as 16 QAM, 8 PSK. At the same the circuit complexity of receiver is also low because we have used ML detection in receiver side whose complexity depends on constellation points of modulation.

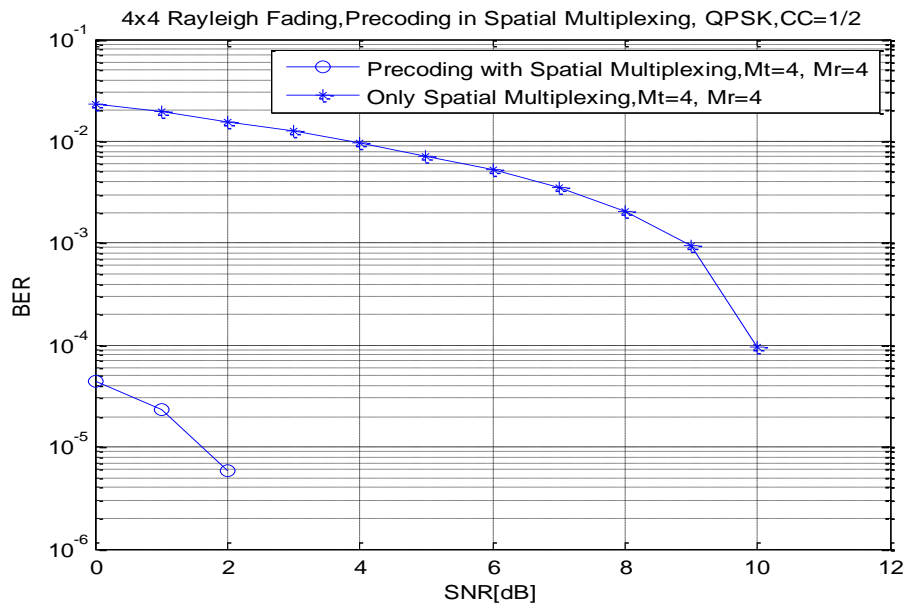

Fig.2. Precoder performance in Spatial Multiplexed MIMO system and with channel coding using $M_t=4$ and $M_r=4$.

Furthermore, we have not used STBC in transmitter side so it does not need to use maximum ratio combiner (MRC) in the receiver side. As a result the complexity of both transmitter & receiver has reduced.

It can be observed from the Fig.2 that there is approximately 9dB gain of the proposed precoder over the spatial multiplexing system in the entire SNR region. We can also see from the Fig.2 that at 2dB SNR there is the BER of $10^{-5.5}$ for our proposed precoder design. On the other hand we have seen that at 2dB SNR there is the BER of 10^{-3} , $10^{-0.9}$ for (W. Huang 2006), (Ami Wiesel 2006) respectively. Whereas at 2dB SNR there is the packet error rate (PER) of $10^{-0.5}$ for (Eddy Chiu 2012). In addition at 2dB SNR there is the symbol error rate (SER) of $10^{-0.1}$ for (O. Simeone 2003).

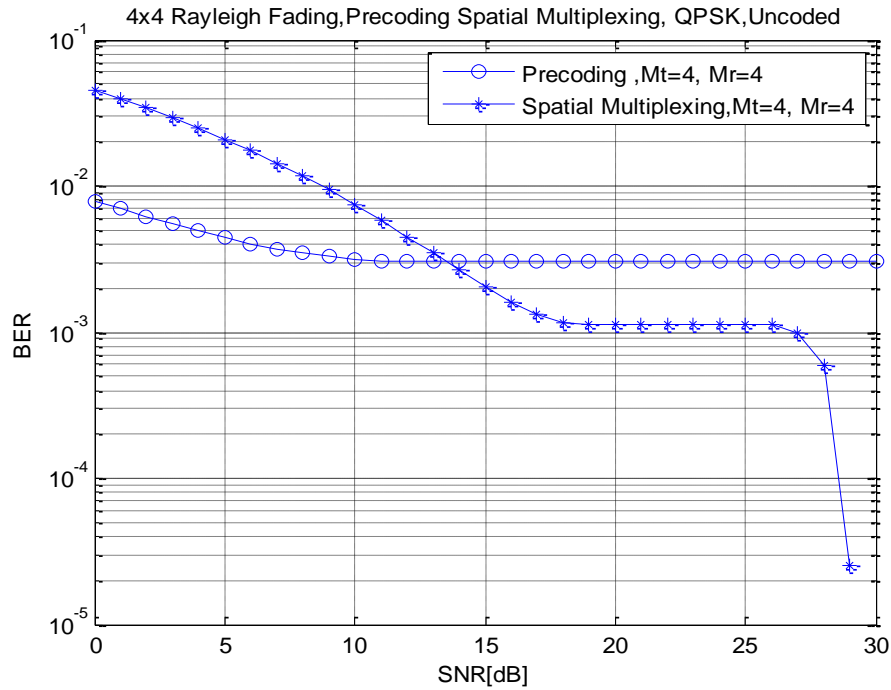

Fig.3. Precoder performance in Spatial Multiplexed MIMO system and without channel coding using $M_t=4$ and $M_r=4$.

From the above results, it is clear that the proposed precoder scheme outperforms existing scheme in terms of system BER. In contrast, proposed scheme is found to be more robust against STBC, but it does require additional antennas to implement. From the Fig.3, it can be seen that the performance of precoder depends on the system setup i.e. mostly on the channel coding.

6. CONCLUSION

In this paper, we derived the linear precoder structure for spatial multiplexing MIMO channels with perfect knowledge of channel state information, subject to a total transmit power constraint. From the results derived herein, we showed that the power allocation on the eigen values of the precoder is given by the water-filling algorithm and hence the proposed precoder allocates more power to the dominant channels. Simulation results show that significant precoding gain can be achieved by using the proposed precoder design.

Acknowledgement

The authors would like to thank the EEE department of Rajshahi University of Engineering & Technology of Bangladesh for supporting their research. The authors also wish to thank Dr. Shaikh Enayet Ullah for helpful discussions and suggestions on the manuscript.

References

- Le-Nam Tran, Mats Bengtsson & Björn Ottersten(2012). Iterative Precoder Design and User Scheduling for Block-Diagonalized Systems. *IEEE transactions on signal processing*, 60, no.7.
- V. Tarokh, N. Seshadri & A. R. Calderbank(1998). Space-time codes for high data rate wireless communication: Performance criterion and code construction. *IEEE Transactions on Information Theory*, 44, 744-765.
- V. Tarokh, N. Seshadri and A. R. Calderbank(1999). Space-time block coding for wireless communications: Performance results, *IEEE Journal on Selected Areas in Communications*, vol. 17, pp. 451-460.
- Samuel C. Yang (2010). *OFDMA System Analysis and Design*. 1st ed., United States of America, Artech House.
- W. Huang, Edward K.S. Au & Vincent K. N. Lau(2006). Linear Precoding for Space-Time Coded MIMO Systems using Partial Channel State Information. *ISIT*, Seattle.
- H. Weingarten, Y. Steinberg & S. Shamai(2006). The capacity region of the Gaussian multiple-input multiple-output broadcast channel. *IEEE Trans. Inf. Theory*, 52, no. 9, 3936–3964.
- S. Vishwanath, N. Jindal & A. Goldsmith (2003). Duality achievable rates and sum-rate capacity of Gaussian MIMO broadcast channels. *IEEE Trans. Inf. Theory*, 49, 2658–2668.
- P. Viswanath & D. Tse(2003). Sum capacity of the vector Gaussian broadcast channel and uplink-downlink duality. *IEEE Trans. Inf. Theory*, 49, no. 8, 1912–1921.
- Umesh Phuyal, Satish C. Jha & Vijay K. Bhargava(2012). Joint Zero-Forcing Based Precoder Design for QoS-Aware Power Allocation in MIMO Cooperative Cellular Network. *IEEE Journal on selected areas in communications*, 30, no.2.
- Jungyong Park, Byungju Lee & Byonghyo Shim (2012). A MMSE Vector Precoding with Block Diagonalization for Multiuser MIMO Downlink. *IEEE transactions on communications*, 60, no. 2.
- Ezio Biglieri, Robert Calderbank, Anthony Constantinides, Andrea Goldsmith, Arogyaswami Paulraj & H. Vincent Poor (2006). *MIMO Wireless Communications*. 1st ed., New York, Cambridge University Press.
- T. Cover & J. Thomas(1991), *Elements of Information Theory*. United States of America, John Wiley & Sons.
- O. Simeone, U. Spagnolini & Y. Bar-Ness (2003). Linear and Non-linear Precoding/decoding for MIMO Systems using the Fading Correlation at the Transmitter. 4th IEEE workshop on signal processing advances in wireless communications.
- Ami Wiesel, Yonina C. Eldar, & Shlomo Shamai(2006). Linear Precoding via Conic Optimization for Fixed MIMO Receivers. *IEEE transactions on signal processing*, 54, no. 1.
- Eddy Chiu, Vincent K. N. Lau, Shunqing Zhang & Bao S. M. Mok(2012). Precoder Design for Multi-Antenna Partial Decode-and-Forward (PDF) Cooperative Systems with Statistical CSIT and MMSE-SIC Receivers. *IEEE transactions on wireless communications*, 11, no. 4.